

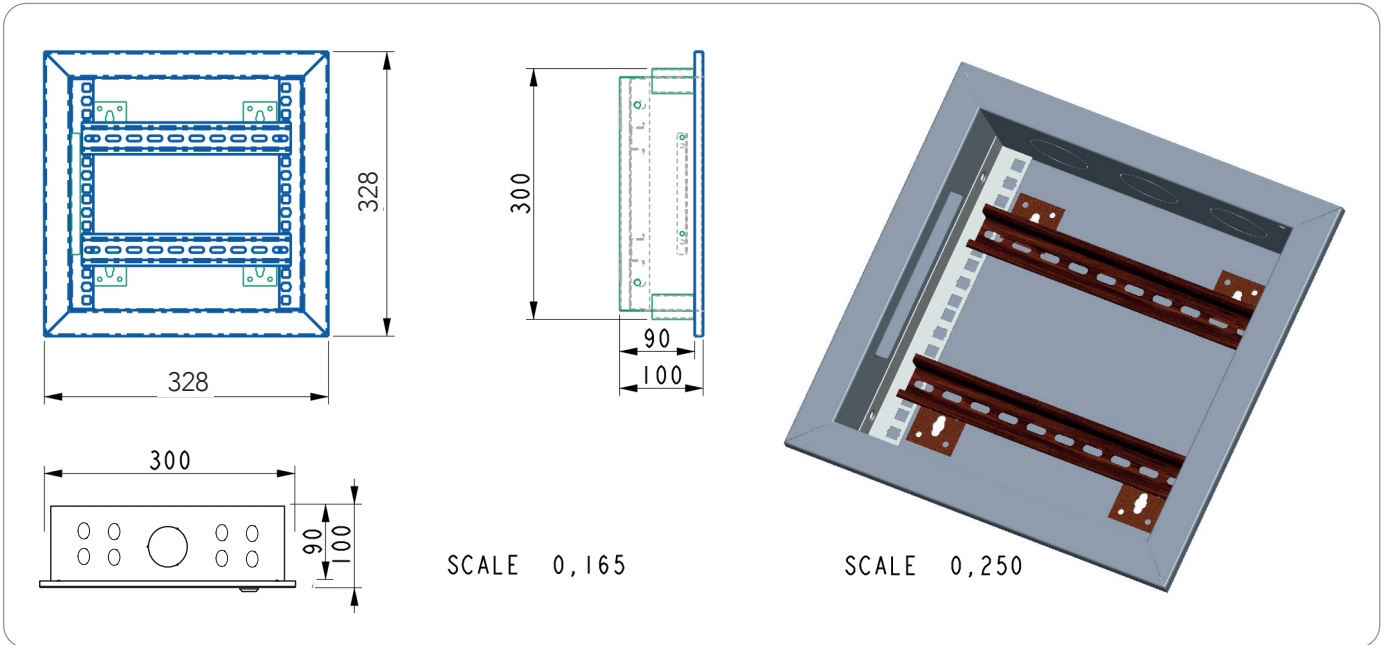

## DESCRIPTION

Voltan Flush Series rack mount equipment for Copper/ Fiber cabling, telecommunications, IT, Industrial and Residential where by Space-saving Design installations required. Designed with toughened glass front door providing greater protection. Reliable and rigid construction ensure max 35Kg static loading capacity. Flush mount design allows the ONU to be installed neatly within a wall, keeping it out of sight and maintaining a clean aesthetic appeal and extremely easy for assembling.



SCALE 0,165

SCALE 0,250

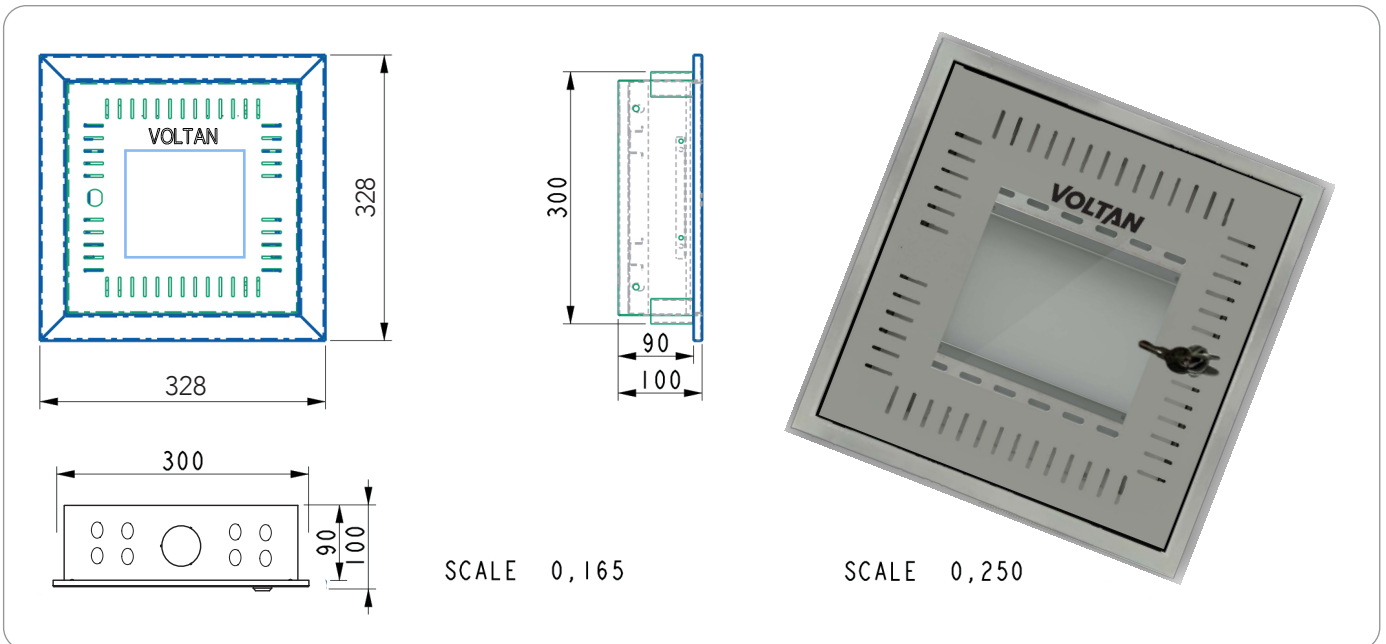

SCALE 0,165

SCALE 0,250

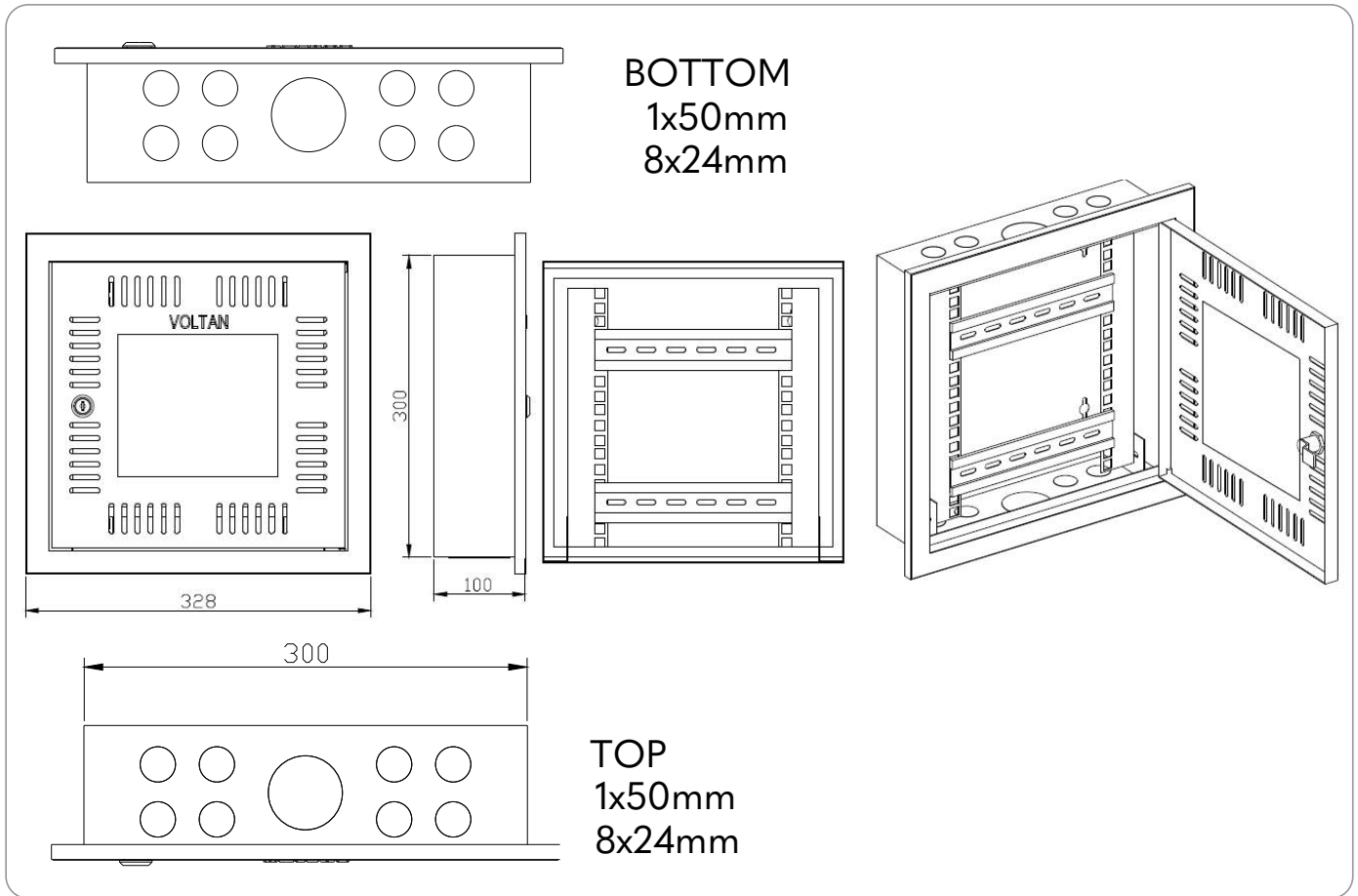

## DESIGN

S/No.	Name	Quantity
1	Frame body	1
2	Horizontal bracket	0
3	Vertical rail	2
4	Top cover	1
5	Bottom panel	1
6	Front door	1
7	Rear panel	1
8	Side panel	2
9	Mounting pane	1
10	Color	RAL 9010

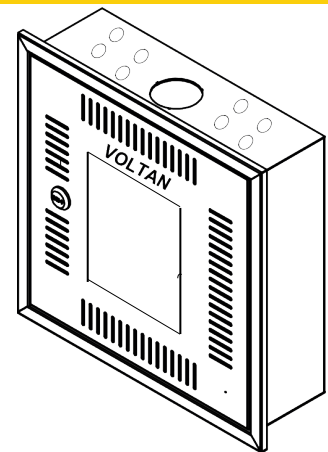

## Note:

This Enclosure designed to install 10 inch mounting accessories

The dimensions and specifications in this document are for reference purposes only and are subject to change without notice.

## ORDERING INFORMATION

Part Number	Description
VFNC3310GD	Voltan Flush mounted Network Cabinet with Glass Door - 300 x 300 x 100 mm